

SERIES

SC



574 WEST OTTERMAN STREET
 POST OFFICE BOX 70
 GREENSBURG, PA 15601-0070
 TELEPHONE: 724-834-7300
 FAX: 724-830-2871

MODEL NO. 4695163 / UL FIRE RATED / STC 46 / FULL LIGHT GLAZED SOUND CONTROL DOOR AND FRAME ASSEMBLY / SINGLE COMPRESSION SEALS

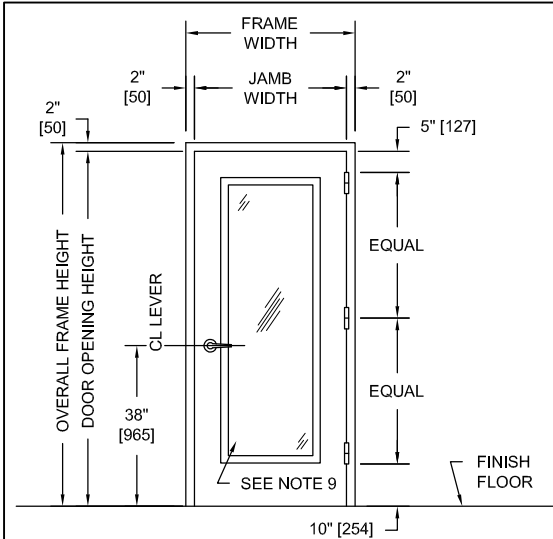

PUBLIC SIDE ELEVATION
 RIGHT HAND REVERSE BEVEL SHOWN

NOTES:

1. All exposed surfaces of door and frame to receive one coat of rust inhibitive prime paint.
2. Door bottom requires flush level sealing surface. Wood, aluminum, or stainless steel threshold recommended. Do not seal against carpet.
3. Frame is equipped with Overly single "H" compression seals at head and jambs. Door is equipped with an Overly Super "H" door bottom.
4. Door weight is 11.9 pounds per square foot.
5. Door can be equipped with standard builders hardware, Customer to specify. Concealed hardware is not recommended for acoustical doors.
6. Frames equipped with masonry anchors must be grouted full in field. Bolt-in type frames must have all voids in head and jambs packed with 6 to 12 pound density mineral wool and all voids between wall and frame continuously caulked.
7. UL 3/4 hour labels can be provided on doors equipped with up to 1,296 square inches of vision light. UL fire labels available in compliance with UL10B and UL10C/UBC7-2. Consult factory for specifics.
8. Unit tested as single door at Riverbank Acoustical Laboratories. Results are described in Test Report No. TL95-163 with sound transmission results as shown in chart below.
9. Door tested acoustically with 1,728 square inch vision light. Customer to specify size.
10. Door construction is covered by US Patent No. 5,417,029.

SECURED AREA (INTERIOR)

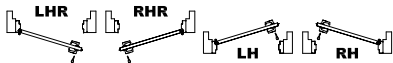

**(KEY) SIDE
 PUBLIC AREA (EXTERIOR)**

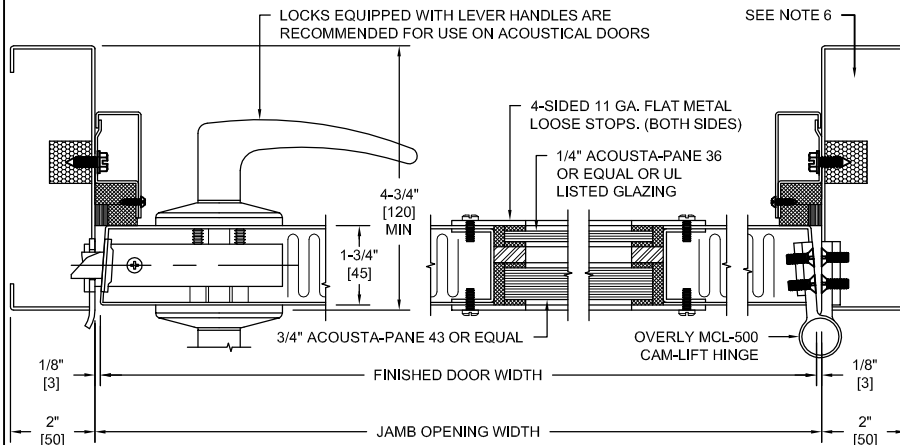

HORIZONTAL SECTION

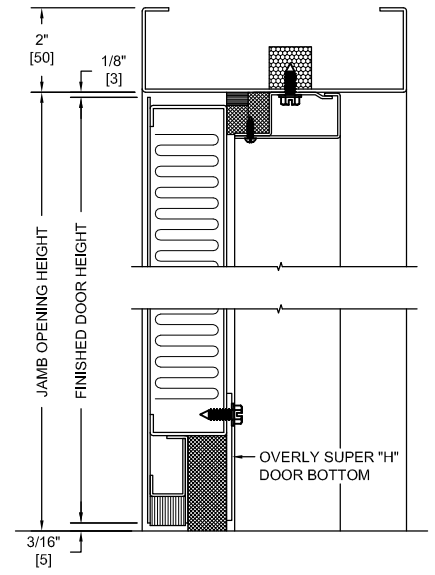

VERTICAL SECTION

SOUND TRANSMISSION LOSS IN dB AT FREQUENCY / HERTZ																	
100	125	160	200	250	315	400	500	630	800	1000	1250	1600	2000	2500	3150	4000	5000
27	27	35	35	33	35	41	44	45	46	48	50	53	54	54	54	52	53

ALL DIMENSIONS
 BOTH IN INCHES
 AND MILLIMETERS