



Installation Instructions
For
2-3/4" & 3" Acoustical Panel Door Units

Dual Adjustable
Dual "H" Seals
And
Super "H" Door Bottoms

INS-5

General Information

The proper performance of most manufactured building products depends not only on how they are made, but how they are installed. This is particularly true of **Acoustical Door** units. Anyone acquainted with building construction knows that the proper installation of the frames and doors is an operation that requires great skill and care. Even the best designed and most carefully made frames and doors, if improperly installed, will not function or perform to their intended maximum effectiveness. Additionally, **Acoustical Door** openings require careful adjustment of the perimeter sealing systems in order to obtain the desired level of acoustical performance.

Overly Door Company is concerned that our product is properly handled and protected after delivery, and that the necessary care and skills are exercised in the setting of our frames and hanging of our doors. It is important to all concerned, therefore, that attention be given to the essential requirements of good practice in field installation work. Use of these installation instructions in combination with the approved shop drawings and your attention to good workmanship will provide the proper installation and operation of Overly Acoustical Doors and Frames.

Delivery and Receiving of Materials

Acoustical Doors and Frames are fabricated in accordance with shop drawings that have been approved by the architect or design engineer. Preparations for hardware and/or other items to be supplied by others are provided in accordance with the information provided to Overly by the hardware supplier or by those other suppliers or trades with whom the work is being coordinated.

Should any material be damaged in shipment, claims should immediately be filed by the receiving party, who should notify the delivering carrier's regional office by telephone or in writing, requesting inspection of the damaged material. If desired, Overly Door will cooperate by furnishing copies of shipping papers or other pertinent information to help expedite the claim. Accepted materials become the customers responsibility to protect and store accordingly.

If a claim is to be made for any error or deficiency in the materials supplied, it is imperative that Overly be notified in writing before initiating any corrective action in the field. Overly Door has its own field representatives who are qualified not only to do expert repair work but to determine whether the fault lies with the manufacturer or with some other party.

On-Site Storage

Improper storage of **Acoustical Doors and Frames** at the construction site often results in the deterioration of the shop primer coat of paint. Such deterioration is a continuing source of aggravation to all concerned.

Particular attention must be given to steel products which are to be stored having only one coat of shop primer if corrosion is to be avoided. Because the protective shop primer must be porous to properly receive and hold top coats, water or moisture in contact with prime coated steel will seep through to the steel by capillary action. An electrolytic action then follows, resulting in corrosion and causing the paint to lose adhesion. The presence of oxygen at the water-air interface behind the loosened paint film accelerates corrosive action and further prime coat deterioration.

Manufacturers of metal acoustical doors and frames have found that one week of exposure to water because of improper storage is equivalent to at least a year of outdoor exposure to the elements.

It is imperative that those parties who are responsible for the storage of primed metal work at the job-site be carefully instructed as to proper storage procedures. All ferrous metal products should be stored where they are least likely to be exposed to contact with water.

The following steps should always be observed when storing **Acoustical Doors and Frames** at the job-site:

- A. Store all materials in a dry area under cover.
- B. Place all material on planking or blocking at least 4" off of the ground, 2" off of slab or paved area.
- C. Do not stack material flat. Store with frames in an upright position.

- D. Provide, by means of wood or styrofoam strips, a space of at least 1/4" between all units, to allow air to circulate between them.
- E. Do not permit cardboard or paper to become wet and come in contact with the frames. If this should occur, remove them immediately.

Uncrating Instructions

Depending on the size of your particular order and the manner in which items required for the door and frame installation were ordered, the crate which you have received may contain one, two or several acoustical units. The quantity and type of items provided by Overly can be found on the packing list located on the outside of the crate. Many times, other items such as glass, hardware, etc., that are required for a complete opening, is provided by an outside source and should be coordinated with the Overly door and framing system. As you uncrate, review the packing list and locate the following items for a complete installation:

- A. **Frame** - identification information on the frame can be found on a small white tag located on one of the frame hinge reinforcements. This information includes Overly order number, unit mark number and swing. If a UL Fire Label is provided, it can be found attached to the hinge jamb rabbet.
- B. **Door(s)** - depending on if you have a single or pair of doors, a similar white tag is utilized to identify the door and includes the same information as the frame. If a pair of doors is provided, the mark number will contain an "A" after it for the active leaf, and an "N" after it for the inactive leaf.
- C. **Frame Gasketing System** - the Overly Dual Adjustable, Dual "H" seal gasket retainer system, retainer covers and associated fasteners are packaged together and labeled with the mark number information. If pairs of doors are supplied, the integral astragals for each leaf with associated fasteners are pre-attached to each door leaf of the opening.
- D. **Super "H" Compression Type Door Bottom** - this particular model panel door requires the use of Overly's Super "H" compression type door bottom assembly that is shipped loose in a styrofoam shipping package with associated fasteners and labeled with the mark number information.
- E. **Cam-Lift Hinges** - this particular unit requires the use of Overly cam-lift hinges. These hinges are supplied in a small white box labeled with the words cam-lift hinges and the opening mark number and swing.
- F. **Anchors** - Frame anchors have been provided. Check packing list and shop drawings as to type required and supplied.
- G. **Pink Noise Source** – The CD is located inside the installation instruction envelope. Place in a safe place for use later during gasket installation and adjustment.
- H. **Mounting Brackets** - If stop mounted closers or latching hardware are to be used, "Z" or "L" shaped brackets are supplied with associated fasteners and labeled with mark number information. Check packing list to see if any such brackets have been supplied.

Miscellaneous items such as thresholds, locksets, flushbolt, glass, etc., may or may not have been provided by Overly. Be sure to check packing list and shop drawings for further details.

Frame Installation Procedure

Note: Prior to installation of the frame, it is recommended that the installer obtain copies of architect's plans and approved hardware schedule prior to beginning installation.

The frame assembly provided consists of a 4-sided welded unit that was factory inspected prior to shipment to assure that they are square and that no jamb twists have occurred during their fabrication. To minimize misalignment or other damage during shipment, the frames are packed and loaded onto the carrier by personnel experienced in frame packaging. However, in spite of these precautions, the frames can and sometimes do arrive at the jobsite with minor deviations. Should this occur, most out-of-square and misalignment problems can be readily corrected during installation.

Frame anchorage systems are custom designed to accommodate individual project opening requirements to suit specified wall conditions. Therefore, it is necessary to refer to the approved shop drawings for each individual frame for the method of anchorage. The four general types of anchorage covered by these instructions include:

1. Built-in masonry
2. Built-in drywall with wood or channel studs
3. Bolt-in masonry
4. Bolt-in drywall with wood or channel studs

At this time, review the shop drawings for the openings and proceed to the type of installation required. Regardless of the anchorage system required, the installation guidelines must be adhered to. At anytime during the installation of the product, if questions arise, call **Overly Door at 724-834-7300**.

1. Built-in Masonry Partition

- A. Remove temporary steel spreader from bottom of frame.
- B. Use some type of triangular support and bracing device that will securely hold the frame in the exact location and alignment required for proper installation. Usually such bracing is made of wood. However, metal "jacks" or supporters designed specifically for this purpose are commercially available, and their use is recommended.
- C. Cut 3/4" thick temporary wood spreaders to accurate jamb dimensions and locate at 1/3 points of the frame and at the sill.
- D. Check that the frame is square and aligned by measuring the diagonal dimensions and "cross string" the frame to insure that the jambs are properly set. (See Figure 1).
- E. While protecting the frame from accidental abuse, build walls to the frame utilizing the strap anchors attached to the frame, making sure that proper frame alignment is maintained.

Note: As the walls are being built, the frame must be grouted full to ensure maximum acoustical performance. Extreme caution must be exercised while performing this operation to make sure the head does not sag nor the jambs or sill be allowed to bow.

- F. After the frame is permanently built into the wall, with all strap anchors installed and cement and/or grout set, remove the wood spreaders.
- G. Caulk frame continuously around perimeter of frame on both sides at frame/wall interface.

Note: A threshold may be required for the opening. This threshold may or may not have been provided by Overly. Refer to shop drawings as to if one is required, and who may have supplied it. Thresholds must have smooth, flush top surfaces. No textured or fluted thresholds permitted.

- H. If one is required, install at this time between the frame jambs, as shown on the drawings. The threshold should be set in dense mastic or acoustical sealant.

Now Proceed to "Installation of Door(s)" section.

2. Built-in Drywall Partition

- A. Remove temporary steel spreader from bottom of frame.
- B. Use some type of triangular support and bracing device that will securely hold the frame in the exact location and alignment required for proper installation. Usually such bracing is made of wood. However, metal "jacks" or supporters designed specifically for this purpose are commercially available, and their use is recommended.

Note: At this point, the frame must be packed full with 6 to 12 PCF density mineral wool in the form of blanket or board type, to ensure the maximum acoustical performance of the opening.

- C. Cut 3/4" thick temporary wood spreaders to accurate jamb dimensions and locate at 1/3 points of the frame and at the sill.
- D. Check that the frame is square and aligned by measuring the diagonal dimensions and "cross string" the frame to insure that the jambs are properly set. (See Figure 1).
- E. While protecting the frame from accidental abuse, build walls to the frame utilizing the "Z" anchors attached to the frame, making sure that proper frame alignment is maintained.
- F. After the frame is permanently built into the wall, with all anchors installed, remove the wood spreaders.
- G. Caulk frame continuously around perimeter of frame on both sides at frame/wall interface.

Note: A threshold may be required for the opening. This threshold may or may not have been provided by Overly. Refer to shop drawings as to if one is required, and who may have supplied it. Thresholds must have smooth, flush top surfaces. No textured or fluted thresholds permitted.

- H. If one is required, install at this time between the frame jambs, as shown on the drawings. The threshold should be set in dense mastic or acoustical sealant.

Now Proceed to "Installation of Door(s)" section.

3. Bolt-in Masonry Partition

Note: Masonry openings that are to receive preassembled welded frames must be accurately constructed. They should be 1/2" wider than the overall frame width dimension and 1/4" higher than the overall frame height, to provide a clearance on all sides of 1/4" to allow for shimming during installation. Overly recommends the use of metal shims when shimming is required due to the weights of acoustical doors.

Note: At this point, check the approved shop drawings or architects plans to see if the frame is to be grouted full or packed with mineral wool. If the frame is to be grouted full, proceed to **Step A**. If the frame must be packed full, pack all frame cavities full at this time using 6 to 12 PCF density mineral wool in the form of blanket or board type, to ensure the maximum acoustical performance of the opening.

- A. Remove temporary steel spreader from bottom of frame.
- B. Insert frame into prepared opening and shim frame as required to maintain the tolerances shown in Figure 1 and securely anchor the frame to the wall using the anchor bolts of type and dimensions specified on the approved shop drawings. If the frame is UL labeled, UL approved anchors were provided with the shipment for installation, otherwise, anchors may or may not have been provided.
- C. Check that the frame is square and aligned by measuring the diagonal dimensions and "cross string" the frame to insure that the jambs are properly set. (See Figure 1).

Note: If the frame is to be grouted in place, grout at this time with Gold Bond Gypsolite Plaster by National Gypsum or Structo-Lite by US Gypsum or equal. Extreme caution must be exercised while performing this operation to make sure the head does not sag nor the jambs bow. Support frame head and jambs with adequate bracing, removing only after grout has had sufficient time to cure.

- D. Caulk frame continuously around perimeter of frame on both sides at frame/wall interface.

Note: A threshold may be required for the opening. This threshold may or may not have been provided by Overly. Refer to shop drawings as to if one is required, and who may have supplied it. Thresholds must have smooth, flush top surfaces. No textured or fluted thresholds permitted.

- E. If one is required, install at this time between the frame jambs, as shown on the drawings. The threshold should be set in dense mastic or acoustical sealant.

Now Proceed to "Installation of Door(s)" section.

4. Bolt-in Drywall Partition

Note: Drywall openings that are to receive preassembled welded frames must be accurately constructed. They should be 1/2" wider than the overall frame width dimension and 1/4" higher than the overall frame height above the finished floor, to provide a clearance on all sides of 1/4" to allow for shimming during installation. Overly recommends the use of metal shims when shimming is required due to the weights of acoustical doors.

Note: At this point the frame must be packed full, pack all frame cavities at this time using 6 to 12 PCF density mineral wool in the form of blanket or board type, to ensure the maximum acoustical performance of the opening.

- A. Remove temporary steel spreader from bottom of frame.
- B. Insert frame into prepared opening and shim frame as required to maintain the tolerances shown in Figure 1 and securely anchor the frame to the wall using the anchor bolts of type and dimensions specified on the approved shop drawings. If the frame is UL labeled, Overly's standard UL approved anchors were provided with the shipment for installation, otherwise, anchors may or may not have been provided.
- C. Check that the frame is square and aligned by measuring the diagonal dimensions and "cross string" the frame to insure that the jambs are properly set. (See Figure 1).
- D. Caulk frame continuously around perimeter of frame on both sides at frame/wall interface.

Note: A threshold may be required for the opening. This threshold may or may not have been provided by Overly. Refer to shop drawings as to if one is required, and who may have supplied it. Thresholds must have smooth, flush top surfaces. No textured or fluted thresholds permitted.

- E. If one is required, install at this time between the frame jambs, as shown on the drawings. The threshold should be set in dense mastic or acoustical sealant.

Now Proceed to "Installation of Door(s)" section.

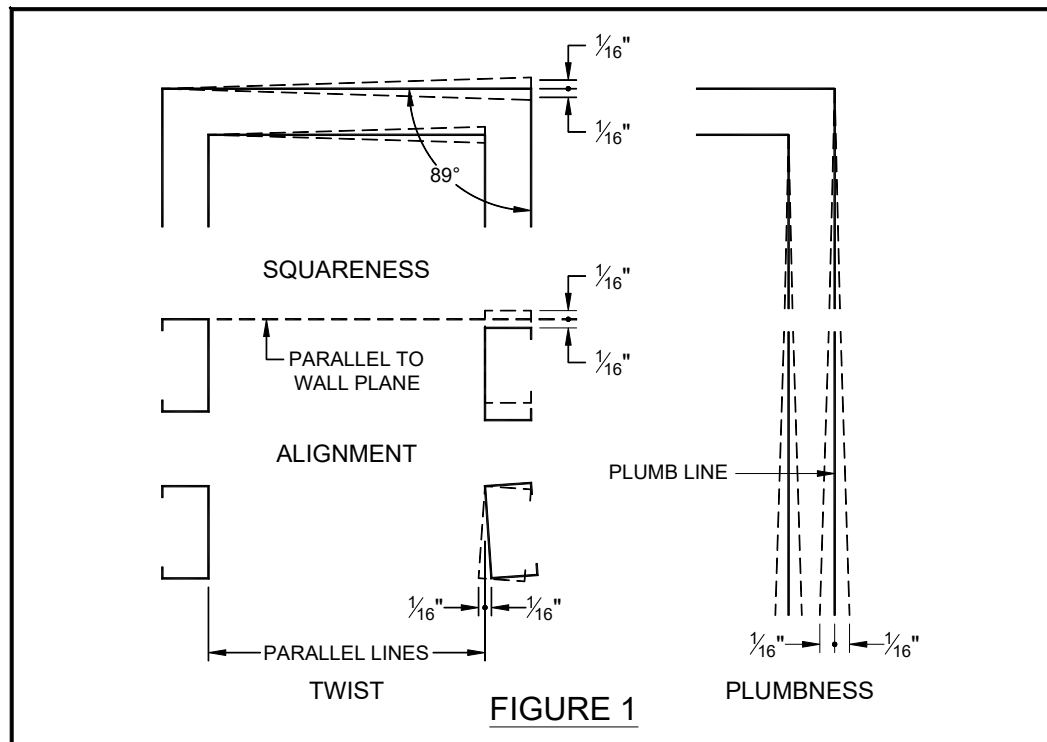

Installation of Door(s)

Note: It is the responsibility of the installer to hang all doors and install all hardware. Holes for the mounting of template hardware are drilled and tapped at the factory. This is not true, however, of preparations for surface mounted items. Adequate reinforcements have been provided for the drilling and tapping of holes for mounting such items. This task is the responsibility of the installer.

Caution: Avoid getting dirt or construction debris around the opening. Keep the sill area clean. This cleanliness will avoid unnecessary damage to the sealing system and ensure ease of later adjustment.

This model acoustical door utilizes Overly Dual "H" type compression frame seals and Overly Super "H" door bottom. The following sections will describe how to hang the door(s), apply and adjust the perimeter sealing system.

- A. Locate cam-lift hinges. The cam-lift hinge is a two part hinge consisting of a frame portion and a door portion. Separate the two portions and mount the leaf with the hinge pin to the frame, and the other leaf to the door with the #12-24 x 5/8" long FH screws provided.
- B. Raise the door to the vertical position and drop the door onto the hinge pins.

Caution: Acoustical panel doors are MUCH heavier than conventional hollow metal doors or standard 1-3/4" acoustical doors. Have adequate assistance to lift door in position.

- C. If opening is pair of doors, install second door leaf at this time.

Note: If inactive leaf requires flush-bolts, install prior to hanging.

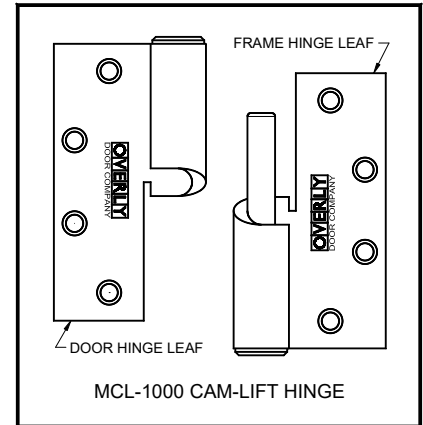

Note: Overly utilizes a variety of lock edge constructions to achieve varied levels of acoustical performance. These types include a welded seamless edge and an isolated edge which contains a black rubber strip. Determine which type of lock edge you have and follow the instructions below.

Seamless Lock Edge: Top flush-bolt may be installed in the normal supplied condition. Bottom flush-bolt rod must be modified by bending to accommodate the presence of the door bottom.

See Figure 2 for dimensional requirements for bending rod.

Isolated Lock Edge: Before either flush-bolt can be installed, the flush-bolt backsets must be modified. Overly has supplied a "Flush-bolt Extension Kit" for each flush-bolt required. Located these kits and follow the instructions enclosed with them. Once the kits are installed to each flush-bolt, the top one may be installed. Bottom flush-bolt rod must be bent to accommodate the presence of the door bottom.

See Figure 2 for bending requirements.

- D. Install locksets in door. If the opening is a pair, install strike and surface-bolts on inactive leaf.

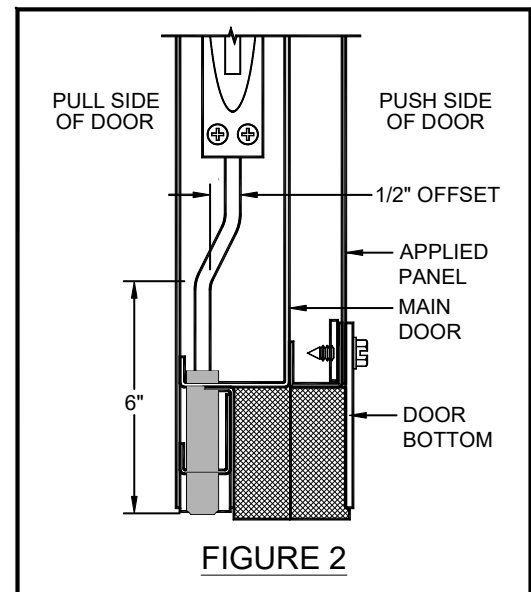

Door(s) Clearance Adjustment Procedure

Before proceeding with installation of retainers and sealing system, it is essential that uniform clearances between door(s) and frame are maintained. The door(s) and frame have been sized to provide the following clearances:

For single doors: 1/8" between Door and Frame Head
1/8" between Door and Frame at Hinge Jamb
1/8" between Door and Frame at Strike Jamb

For pairs of doors: 1/8" between Doors and Frame Head
1/8" between Doors and Frame at Jambs
1/8" between Doors at meeting stile

Adjustments can be made by following the steps outlined below:

Note: Overly recommends the use of metal shims when shimming is required, due to weights of acoustical doors.

To move the door toward the hinge jamb, see Figure 3 and follow these steps:

- A. If shim **S1** is used, the door will move towards the hinge jamb of the frame. If shim **S2** is used, both the door and the hinge barrel will move towards the frame.
- B. If both shims **S1** and **S2** are used, the door will move further towards the hinge jamb of the frame than by using either **S1** or **S2** alone, and the hinge barrel will be moved to the same position as by using shim **S2** alone.

To move the door away from the hinge jamb, see Figure 4 and follow these steps:

- A. If shim **S3** is used, the door will move towards the strike jamb of the frame (or the center of the opening for pairs). If shim **S4** is used, both the door and the hinge barrel will move towards the strike jamb of the frame (or the center of the opening for pairs).
- B. If both shims **S3** and **S4** are used, the door will move further towards the strike jamb of the frame (or the center of the opening for pairs). than by using either **S3** or **S4** alone, and the hinge barrel will be moved to the same position as by using shim **S4** alone.

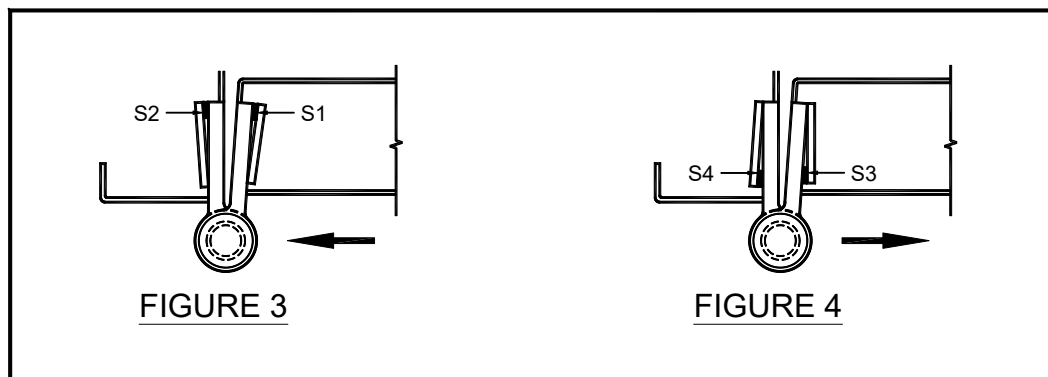

Retainer and Gasket Installation

Note: Prior to installing retainer assemblies, retainers, frames, and doors should be finished painted. It is imperative that paint applied dries completely and forms a smooth, dry, hard surface. At no time should paint be applied to gaskets.

- A. Swing the door(s) to full open position and with the use of the packing list locate all of the items listed in Figure 5.
- B. Fastener package “A” contains item “C” (#14 x ¾” lg. Hex Washer Head Sheet Metal Screw). Use these fasteners to attach item “B” (Door Retainer) to the three jambs.

Using item “D” (Panel Retainer) as a guide, and starting at the bottom of the jamb, insert a fastener into the first slot located in item “B” (Door Retainer) that corresponds to a square notch in item “D”. See Figure 6. Set item “D” aside and continue, up the jamb, inserting fasteners in every other slot. Fasteners should remain finger tight at this point.

Continue with the other jamb following the same steps as previously described.

For the head jamb, slide item “B” (Door Retainer) in from the door side of the frame. Insert item “C” (#14 x ¾” lg. Hex Washer Head Sheet Metal Screw) into the first slot on the other end of the retainer, and continue across the head inserting fasteners in every other slot.

Push the retainers away from the door as far back as they will go. Fasteners should be finger tight.

- C. Measure the Jamb Opening Width and add ¾” to this measurement and carefully cut square ends on a length of item “A” (“H” Seal). Install this seal into the head door retainer with the orientation as shown in Figure 5. The largest exposed surface of felt segment of seal is to go against frame. The small exposed felt surface faces the door.

Note: Make sure to wipe off any dust or foreign matter that may have accumulated on retainers and/or seal.

- D. Install item “A” (“H” Seal), by placing one square end of the seal snugly up against the hinge jamb, then place the other end snugly up against the strike jamb. Work the remainder of the seal into the retainer by placing the center bottom portion in next, and continue to alternate from side to side halving the distance each time.
- E. Measure the jamb opening height from the bottom of the head door seal to the top of the finished floor (or threshold, if used) and add ¾” to this measurement. Again, carefully cut square ends on two lengths of seal. Install this seal into each door retainer with the seal oriented as shown in Figure 5. The largest exposed surface of felt segment of the seal is to go against the frame. The small exposed felt surface faces the door.
- F. On the hinge side place one square end of seal snugly against the head seal, and place the other end snugly against the finished floor (or top of threshold). Continue to work the remainder of the seal into the retainer in the same manner that was described in Step D.
- G. Repeat Step F for the lock side of the frame.
- H. Close and latch the door(s). Push the jamb and head retainers snugly up against the door until you cannot see clearance between the seal and door. Then open the door and torque down all gasket retainer screws until the retainers can only be moved by driving them with a hammer and hardwood block.

Caution: Do not smash the gaskets against the door face. Only light pressure is required for the compression seal to be effective.

- I. Swing the door(s) to the fully open position.
- J. Install item “D” (Panel Retainer) by inserting item “C” (#14 x ¾” lg. Hex Washer Head Sheet Metal Screw) through all remaining slots. See Figure 6.
- K. Measure the jamb opening width and subtract 1 ¼” from this measurement and carefully cut a length of seal. Install this seal into the head panel retainer with the seal oriented as shown in Figure 5. The largest exposed surface of felt segment of the seal is to go against the frame. The small exposed felt surface faces the door.
- L. Install the seal as previously described in Step D.

- M. Measure the jamb opening height from the bottom of the head seal, just installed, to the top of the finished floor (or threshold, if used) and add 3/4" to this measurement. Again, carefully cut squared ends on two lengths of seal. Install this seal into each panel retainer with the seal oriented as shown in Figure 5. The largest exposed surface of felt segment of the seal is to go against the frame. The small exposed felt surface faces the door.
- N. Install the seal as previously described in Step F.
- O. Close and latch the door(s). Push the jamb and head retainers snugly up against the door until you cannot see clearance between the seal and door. Then open the door and torque down all gasket retainer screws until the retainers can only be moved by driving them with a hammer and hardwood block.
- P. Open the door(s) and install the Super "H" door bottom(s) by matching up the 1/4" x 3/4" obround slots of the door bottom with the pre-punched holes located on the narrow side panel skin of the door leaf and securing with the #14 x 3/4" hex washer head screws found in Fastener Package B. Each door bottom has been marked with the opening number prior to shipment. Be sure to push the door bottom as far up as possible before tightening the screws. Trim off door bottom ends to match the door width. See Figure 8.

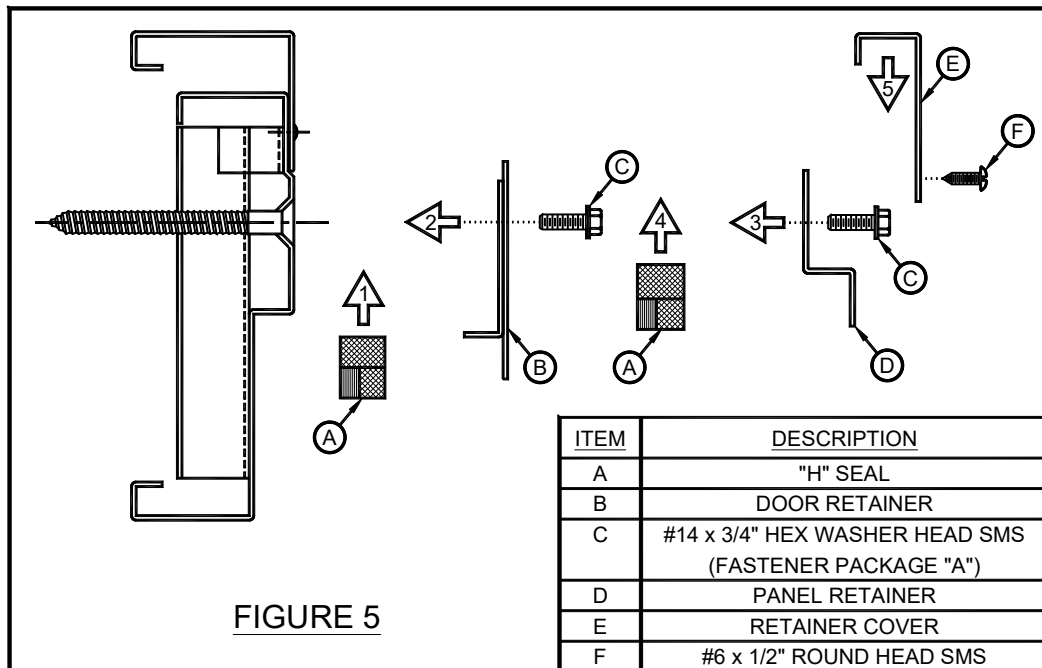

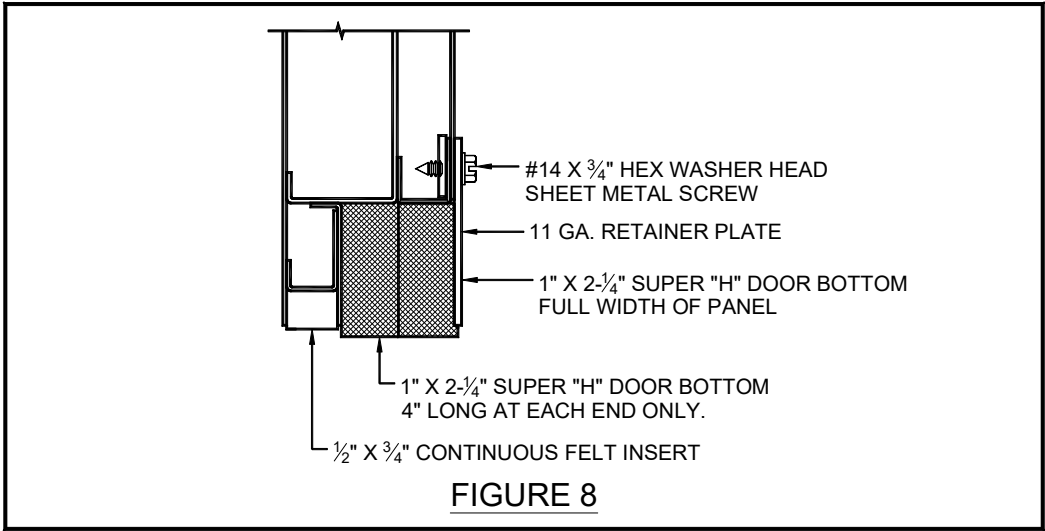
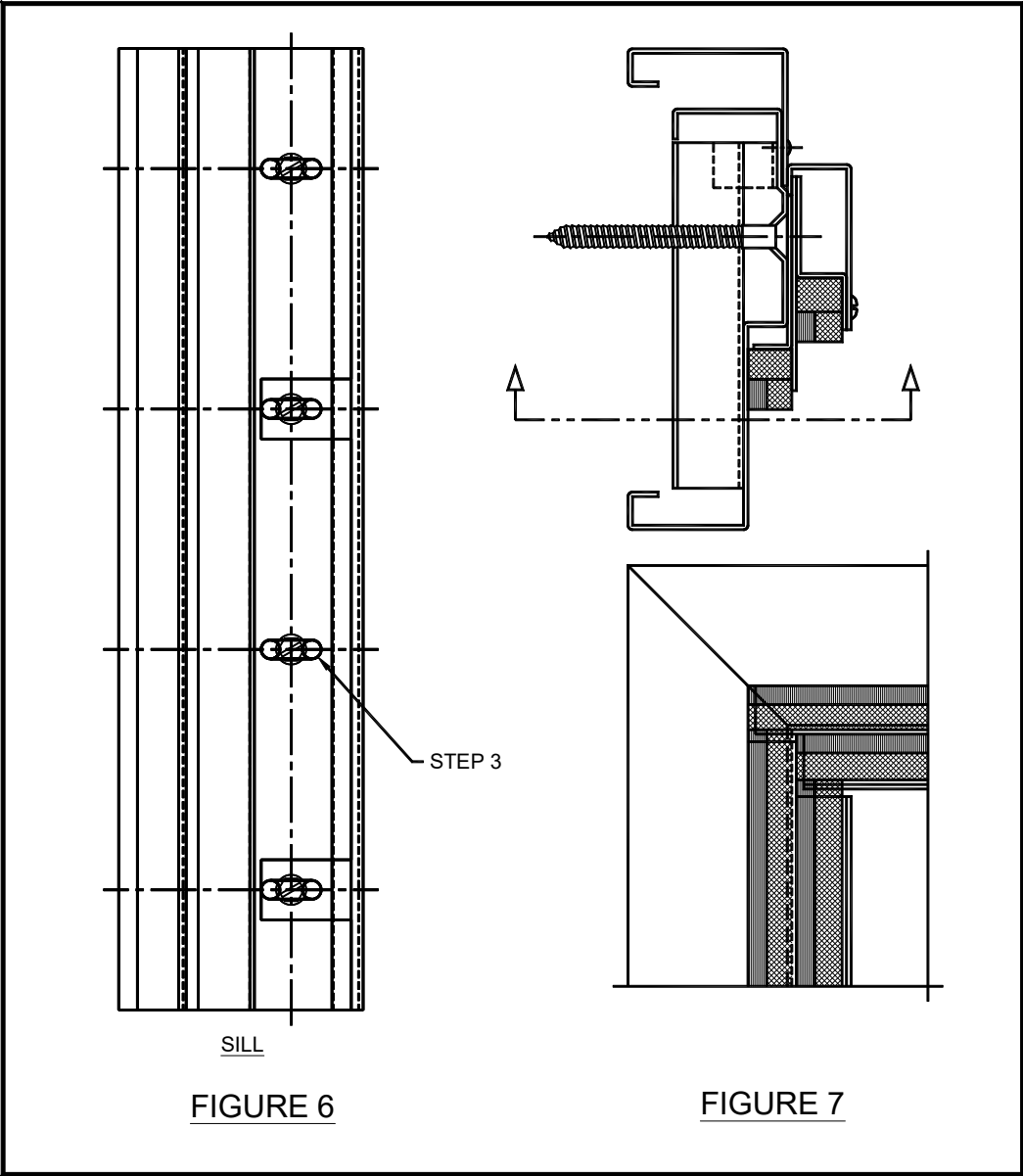

Meeting Stile Astragal Adjustment (Pairs of Doors Only)

Integral astragals and gaskets at meeting stile were factory installed on each leaf. See Figure 9 for orientation of meeting stile. Each astragal comes pre-punched with 1/4" x 3/4" obround slots to provide adjustment in two directions, towards the meeting stile or towards the hinge edge. With the doors in the closed position, inspect the astragal gasketing to see if the active leaf gasket contacts the inactive leaf piece. If not, drive either astragal in the direction necessary to achieve contact with a hardwood block and light hammer taps.

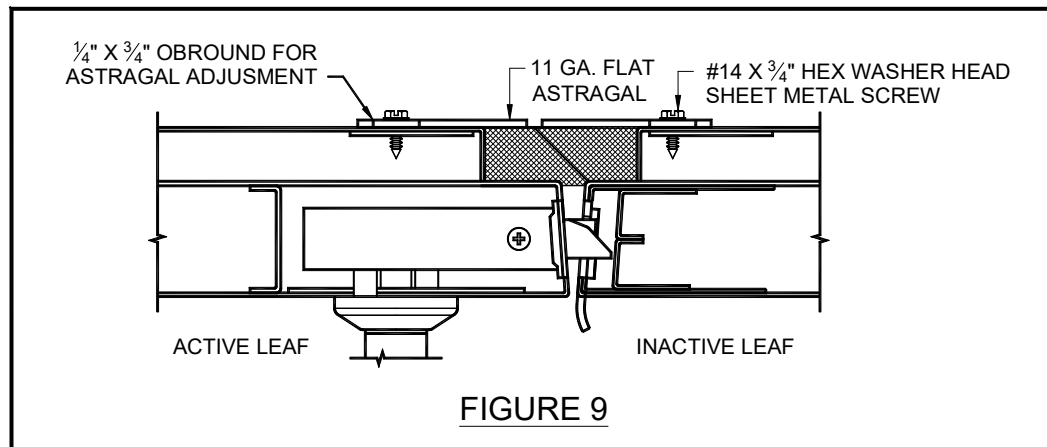

Final Gasket Adjustment Procedure

Required Equipment: A CD player, a mechanics stethoscope, hammer, and hardwood or aluminum block. A doctor's stethoscope may be converted to a mechanics type by replacing the listening end with an 18" long piece of 1/8" diameter copper tubing.

- A. Using the pink noise CD that was provided, place it into the player and set it to a high volume level that is uncomfortable for normal hearing. Locate the player approximately 3 feet from the door on the hinge side.
- B. Close and latch the door.
- C. Apply the "ear" or probe of the stethoscope to the line between the gasket and where it contacts the door. Beginning on the lower hinge side, make a slow first pass around the perimeter of the seal line to detect major leakage points, identifying these major leak points as you go.
- D. Beginning at the hinge side, adjust the gaskets by tapping the retainer to drive it closer to the door at the areas identified in step C. Use the stethoscope after each adjustment to verify the changes in sound attenuation.

Note: It is important to note that the purpose of the compression seal is to reduce and minimize the sound attenuation of the unit. The ideal setting for the seals is if the attenuation is of a uniform distribution.

- E. When noise level is uniform along the hinge side gasket, work across the head gasket retainer from the hinge to latch jambs.
- F. Repeat the same procedure along the latch side gasket retainer.
- G. Repeat the same procedure along the door bottom by lightly driving the door bottom cover plate towards the top of the sill/threshold.

Caution: All types of door bottoms have inherent leaks at the corners; therefore, when fine tuning with the stethoscope an increase in sound levels to be expected. Do not attempt to put excessive pressure on the door bottom gasket to eliminate this condition. If excessive force is tried, the condition will remain the same, but the door bottom neoprene will be damaged.

- H. Repeat the same procedure along meeting stile astragals by lightly driving the astragals toward each other.

- I. Fine tune the installation by once again running the stethoscope around the seal line to ensure a uniform level of sound attenuation has been achieved. If acoustical leaks are discovered, drive the gasket retainer toward the door with light hammer taps.

Note: If leaks persist at the top corners, apply a small amount of RTV silicone sealant to the butting edges of the gasket and allow to cure. This should eliminate the condition. Some leakage is normal at the corners, especially the bottom ones.

- J. Firmly torque down the gasket retainer screws. Locate retainer covers and **Fastener Package C** containing the #6 x 1/2" long round head sheet metal screws. The steel covers are pre-punched with mounting holes. Use these holes as a template for drilling the retainers for the sheet metal screws.

Note(s): Do not substitute Fastener Package C (#6 x 1/2" long round head sheet metal screws) with self-drilling type screws for mounting retainer covers. Self-drilling screws will cause the "H" seals to bulge due to pushing metal chips into the neoprene portion of the "H" seal gasket. This will have a **negative affect on the STC rating** of the opening.

Do not caulk around the perimeter of any retainer covers (Including jambs and head) where the retainer meets the frame on the opening. Covers are meant to be removable at all times.

"Z" or "L" Bracket Instructions

At no time should any hardware item be mounted to the retainer stop system. For situations that require the need for stop mounted hardware, Overly provides a "Z" or "L" shaped bracket to accommodate this. The "L" bracket is supplied on frames with a jamb depth of less than 7-1/2", while the "Z" bracket is supplied on frames with a jamb depth of 7-1/2" or greater. Figure 10 shows the height of the brackets. Use this dimension in combination with the device manufacturers instructions and mount hardware accordingly.

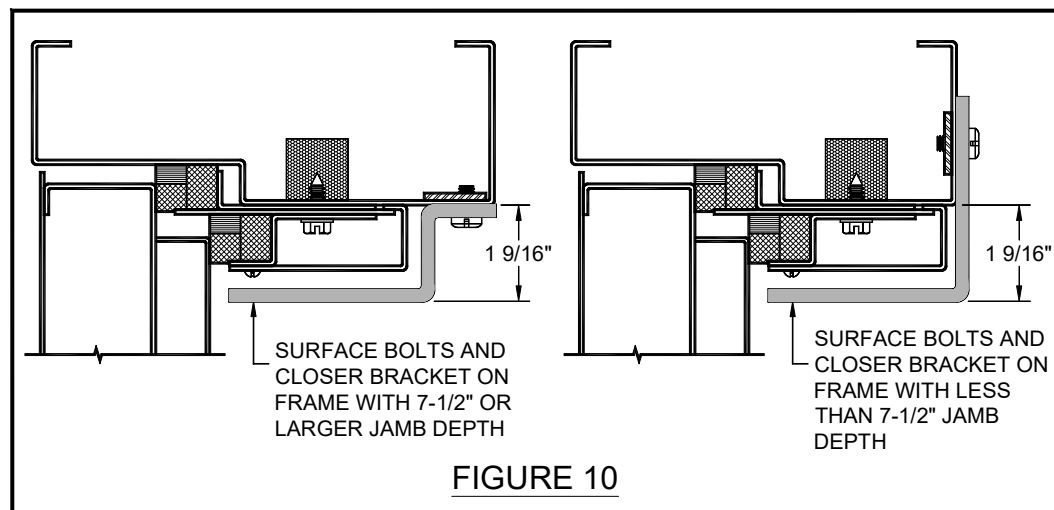

FIGURE 10