

Supplemental Installation Instructions

Clamp-on Single Glazed Vision Light Kit for Wood Acoustical Doors

Introduction:

These installation instructions are to be used for glazing **Overly Acoustical Wood Doors** which require a single glazed vision light. This type of vision light requires the following components:

- Item 1.** A two-piece metal clamp-on framing system with #8 x 2" long Oval Head Sheet Metal fastening screws which have been supplied and shipped loose by Overly.
- Item 2.** 1/2" wide x 3/16" thick adhesive backed sponge neoprene in sufficient length to glaze vision light as shown in Figure 1 below, which has been supplied and shipped loose by Overly.
- Item 3.** 1/4" thick Laminated or Wire glass. Glass may be provided by Overly or by another outside source. Check shop drawings and packing lists to identify glass type and supplier.

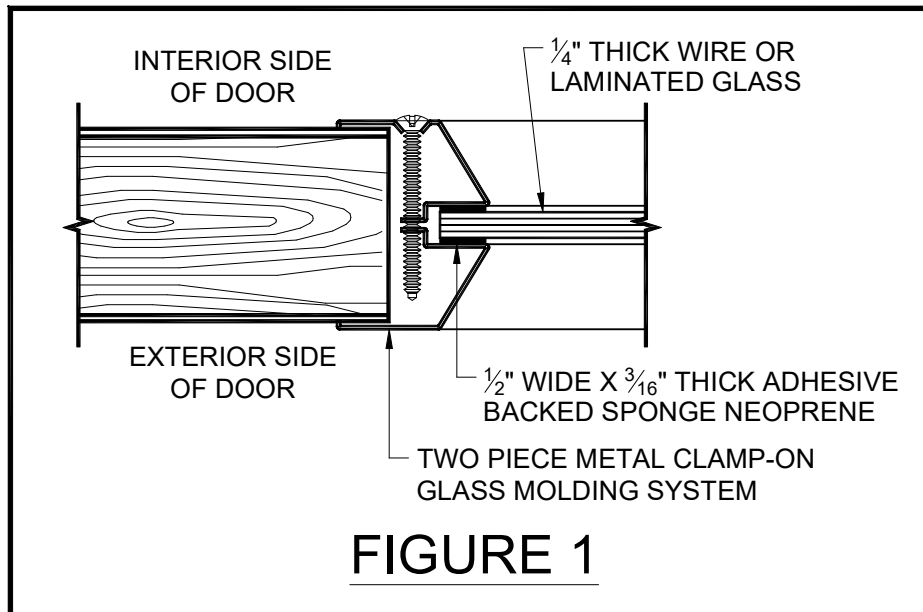

Installation:

- Step 1.** Locate 1/2" wide x 3/16" thick adhesive backed neoprene. On both halves of the metal framing system, apply the neoprene around entire frame perimeter as shown in Figure 1.
- Step 2.** Insert portion of metal frame without fastener holes in exposed face into the cutout prepared in door from the exterior side.
- Step 3.** Lay in glass, followed by inside frame and secure with supplied fasteners.

Caution: Do not overtighten fasteners as it may cause permanent deformation to the frame. It is recommended to tighten fasteners in an alternating sequence to ensure balance of compression.