

SERIES

SC

OVERLY DOOR COMPANY

574 WEST OTTERMAN STREET
POST OFFICE BOX 70
GREENSBURG, PA 15601-0070
TELEPHONE: 724-834-7300
FAX: 724-830-2871

MODEL NO. 5292272 / STC 52 / DUAL GLAZED / SOUND CONTROL FIXED WINDOW ASSEMBLY / NEOPRENE GLAZING

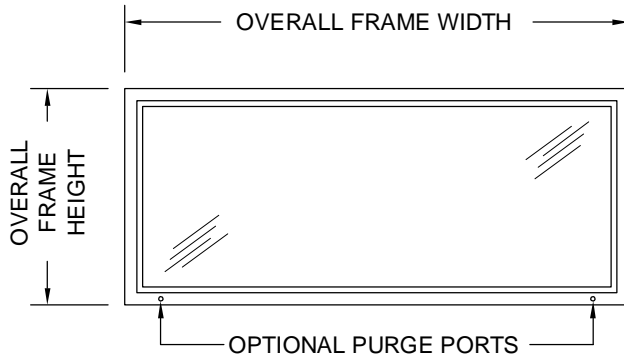

ELEVATION

NOTES:

1. All exposed surfaces of frame to receive one coat of rust inhibitive prime paint.
2. Unit weight, including frame, glass, and glazing, is 12.5 pounds per square foot.
3. Frames equipped with masonry anchors must be grouted full in field. Bolt-in type frames must have all voids in head, jambs, and sill packed with 6 to 12 pound density mineral wool.
4. Unit may be provided with two (2) optional purge ports.
5. Unit can be UL Fire Labeled and remain acoustically certified when it is glazed with one pane of Acousta-Pane 36, 1/4" laminated glass and one pane of up to 5/16" thick UL listed glass such as FireLite brand Ceramic glass.
6. All voids between wall and frame must be continuously caulked

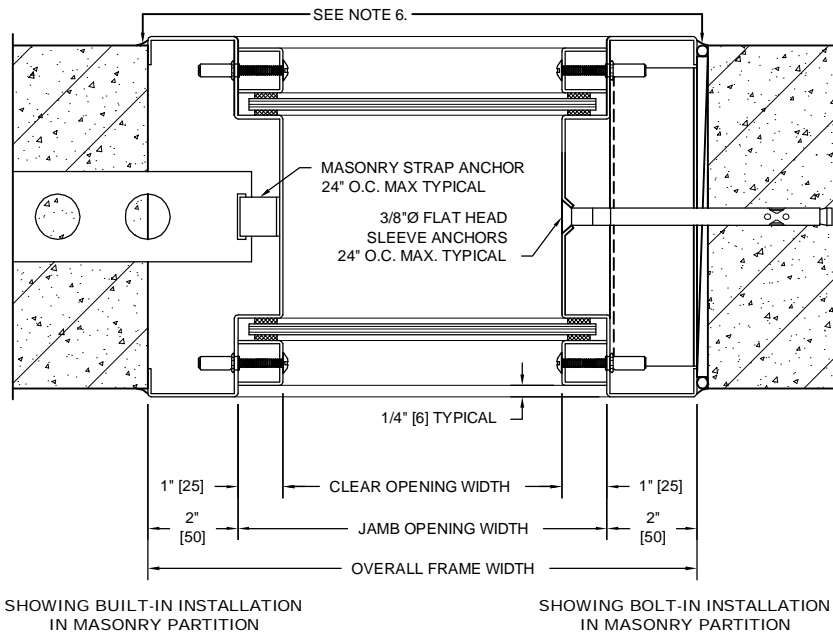

HORIZONTAL SECTION

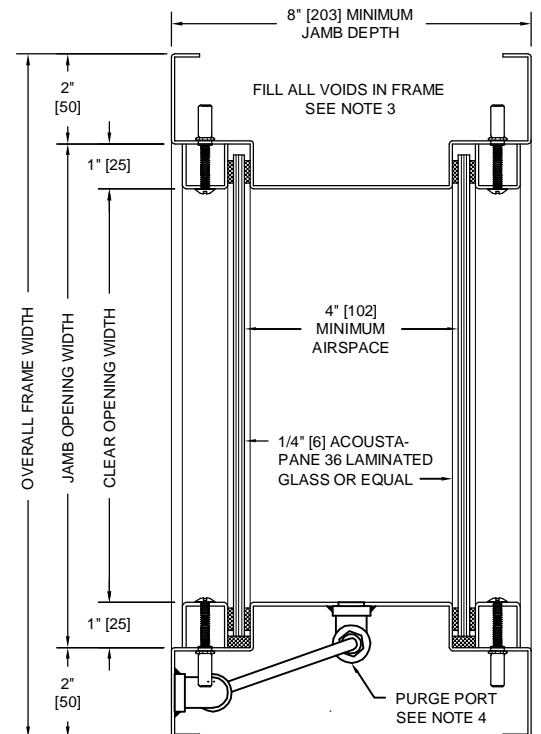

VERTICAL SECTION

SOUND TRANSMISSION LOSS IN dB AT FREQUENCY / HERTZ																	
100	125	160	200	250	315	400	500	630	800	1000	1250	1600	2000	2500	3150	4000	5000
28	37	32	37	39	43	46	50	52	55	56	58	60	61	61	63	66	68

ALL DIMENSIONS
BOTH IN INCHES
AND MILLIMETERS