

# SERIES

# SCW

# OVERLY DOOR COMPANY

574 WEST OTTERMAN STREET  
POST OFFICE BOX 70  
GREENSBURG, PA 15601-0070  
TELEPHONE: 724-834-7300  
FAX: 724-830-2871

## AVAILABLE SOUND CONTROL WALL ANCHORAGE SYSTEMS FOR 1-3/4" THICK WOOD ACOUSTICAL DOOR WITH SINGLE COMPRESSION PERIMETER SEALS

### NOTES:

1. Head and jambs of frames equipped with masonry anchors must be grouted full in field. Bolt-in type frames must have all voids in head and jambs packed with 6 to 12 pound density mineral wool and all voids between wall and frame continuously caulked.
2. For anchorage systems used in all steel or wood stud wall it is recommended a structural tube or reinforced stud is run from and anchored to floor slab and ceiling structure above.

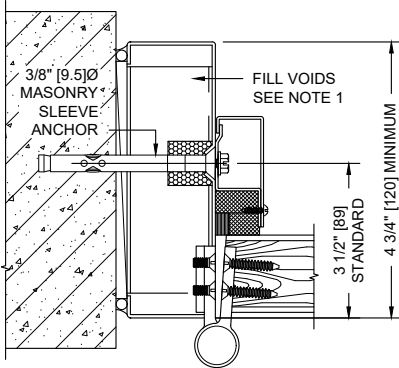

**BOLT IN INSTALLATION  
IN EXISTING POURED CONCRETE WALL  
OR EXISTING MASONRY WALL**

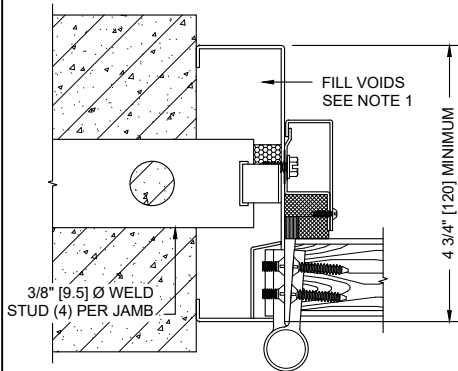

**BUILT-IN INSTALLATION  
IN NEW MASONRY WALL**

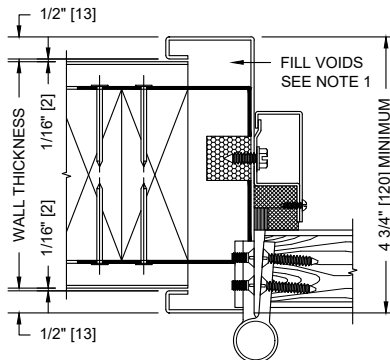

**NAILING CLIP INSTALLATION  
IN NEW WOOD STUD WALL**

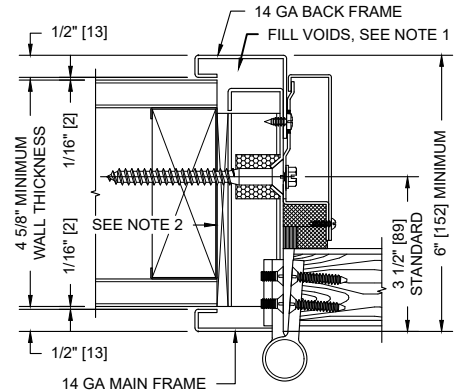

**OPTIONAL SPLIT TYPE FRAME  
FOR BOLT IN INSTALLATION IN  
EXISTING STUD WALL**

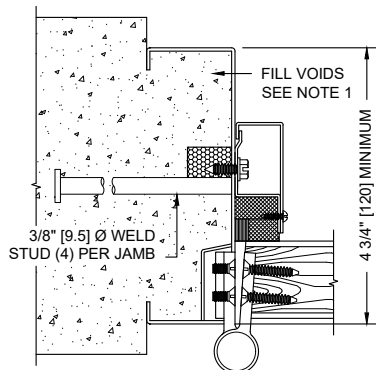

**BUILT IN INSTALLATION  
IN NEW POURED CONCRETE WALL**

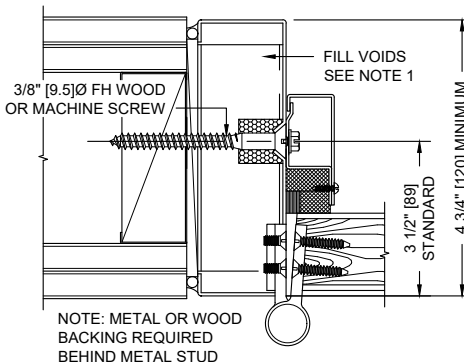

**BOLT-IN INSTALLATION  
IN EXISTING STUD WALL**

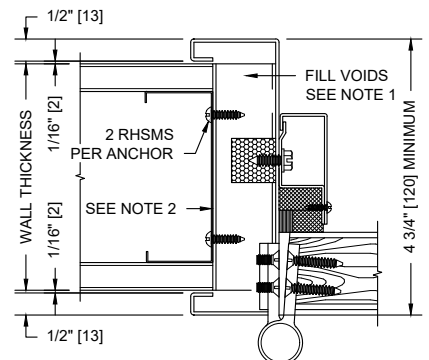

**BUILT-IN INSTALLATION  
IN NEW STUD WALL**