

MODEL NO. 509391 / UL FIRE RATED / STC 50 / PAIR OF FLUSH SOUND CONTROL DOOR AND FRAME ASSEMBLY / COMPRESSION SEALS

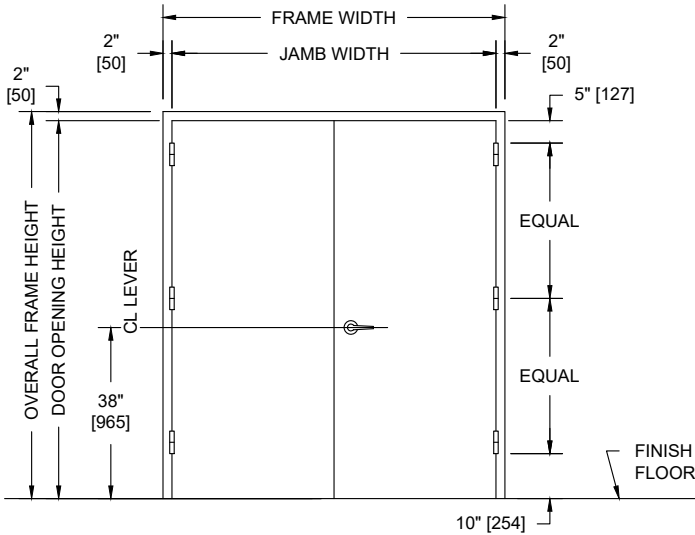

PUBLIC SIDE ELEVATION
RIGHT HAND REVERSE BEVEL SHOWN

NOTES:

1. All exposed surfaces of door and frame to receive one coat of rust inhibitive prime paint.
2. Door bottom requires flush level sealing surface. Wood, aluminum, or stainless steel threshold recommended. Do not seal against carpet.
3. Frame is equipped with Overly Single "H" compression seals at head and jambs. Door is equipped with an overlapping steel astragal at the meeting stile and an Overly super "H" door bottom.
4. Door weight is 10.9 pounds per square foot.
5. Door can be equipped with standard builders hardware, Customer to specify. Concealed hardware is not recommended for acoustical doors.
6. Frames equipped with masonry anchors must be grouted full in field. Bolt-in type frames must have all voids in head and jambs packed with 6 to 12 pound density mineral wool and all voids between wall and frame continuously caulked.
7. UL fire labels available in compliance with UL10B and UL10C/UBC7-2. Consult factory for specifics.
8. Unit tested as pair of doors at Riverbank Acoustical Laboratories. Results are described in Test Report No. TL93-91 with sound transmission results as shown in chart below.
9. Door construction is covered by US Patent No. 5,417,029.

SECURE AREA (INTERIOR)

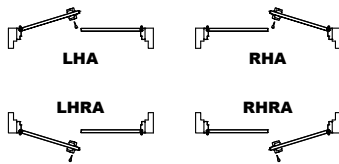

(KEY) SIDE
PUBLIC AREA (EXTERIOR)

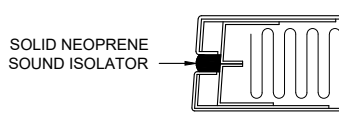

TYPICAL EDGE CONSTRUCTION
ABOVE AND BELOW LOCK AND HINGE CUTOUTS

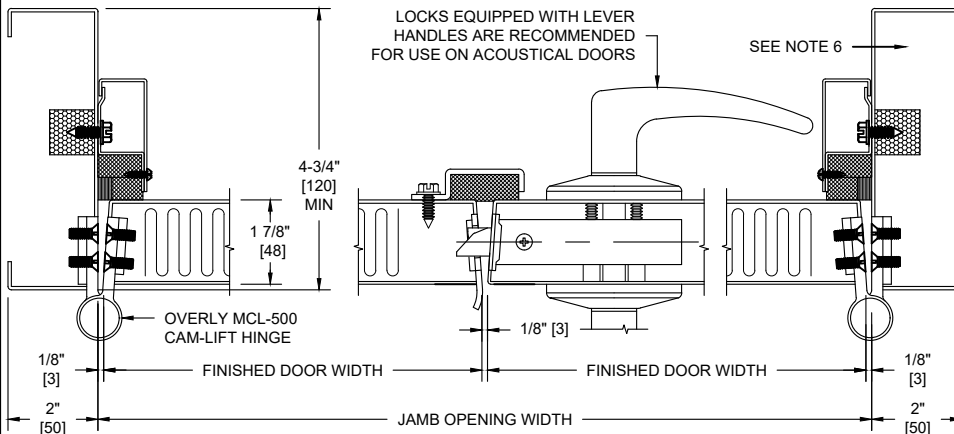

HORIZONTAL SECTION

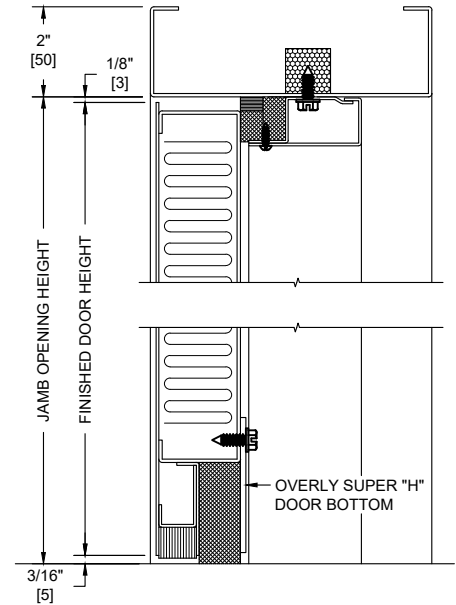

VERTICAL SECTION

SOUND TRANSMISSION LOSS IN dB AT FREQUENCY / HERTZ																	
100	125	160	200	250	315	400	500	630	800	1000	1250	1600	2000	2500	3150	4000	5000
29	31	33	33	36	43	48	49	52	54	54	56	56	59	61	61	61	59

ALL DIMENSIONS
BOTH IN INCHES
AND MILLIMETERS