

# SERIES

# SC

# OVERLY DOOR COMPANY

574 WEST OTTERMAN STREET  
POST OFFICE BOX 70  
GREENSBURG, PA 15601-0070  
TELEPHONE: 724-834-7300  
FAX: 724-830-2871

## MODEL NO. 459573 / UL FIRE RATED / STC 45 / FLUSH SOUND CONTROL DOOR AND FRAME ASSEMBLY / SINGLE COMPRESSION SEALS

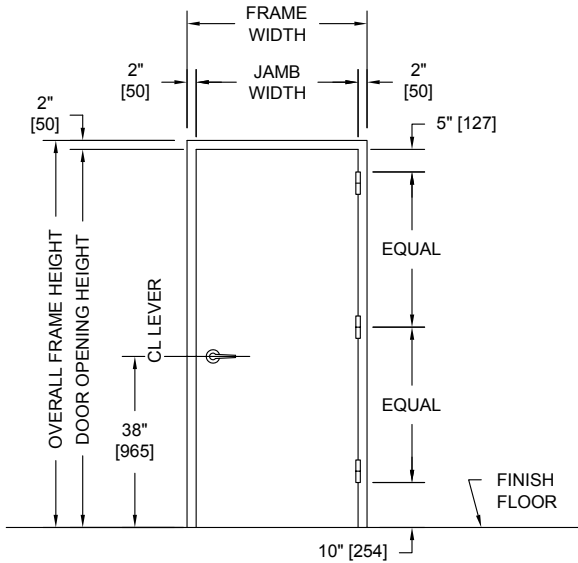

**PUBLIC SIDE ELEVATION**  
RIGHT HAND REVERSE BEVEL SHOWN

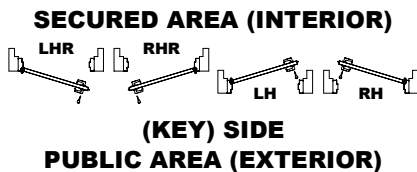

**(KEY) SIDE  
PUBLIC AREA (EXTERIOR)**

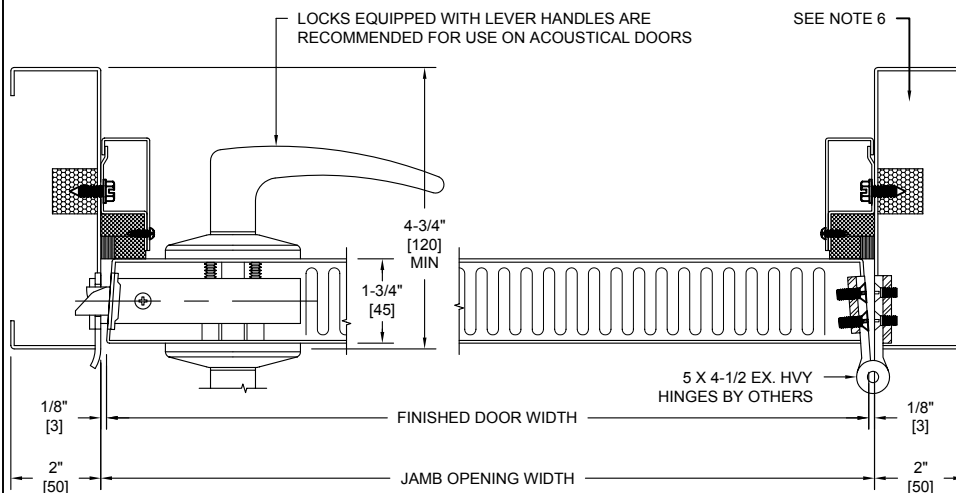

**HORIZONTAL SECTION**

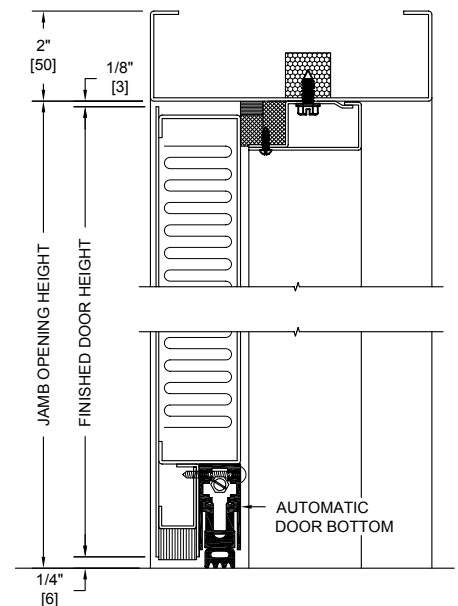

**VERTICAL SECTION**

**NOTES:**

- All exposed surfaces of door and frame to receive one coat of rust inhibitive prime paint.
- Door bottom requires flush level sealing surface. Wood, aluminum, or stainless steel threshold recommended. Do not seal against carpet.
- Frame is equipped with Overly single "H" compression seals at head and jambs. Door is equipped with an automatic door bottom.
- Door weight is 6.8 pounds per square foot.
- Door can be equipped with standard builders hardware. Customer to specify. Concealed hardware is not recommended for acoustical doors.
- Frames equipped with masonry anchors must be grouted full in field. Bolt-in type frames must have all voids in head and jambs packed with 6 to 12 pound density mineral wool and all voids between wall and frame continuously caulked.
- UL fire labels available in compliance with UL10B and UL10C/UBC7-2. Consult factory for specifics.
- Unit tested as single door at Riverbank Acoustical Laboratories. Results are described in Test Report No. TL95-73 with sound transmission results as shown in chart below.
- Door construction is covered by US Patent No. 5,417,029.

SOUND TRANSMISSION LOSS IN dB AT FREQUENCY / HERTZ																	
100	125	160	200	250	315	400	500	630	800	1000	1250	1600	2000	2500	3150	4000	5000
24	29	33	33	33	40	39	41	43	45	47	46	48	49	52	56	57	57

ALL DIMENSIONS BOTH IN INCHES AND MILLIMETERS